

The IEEE 802.11 Protocol

CSMA/CA

(C) Herbert Haas 2004/10/14

Access Methods - CSMA/CA



*"Distributed Foundation
Wireless Medium
Access Control"
(DFWMAC)*

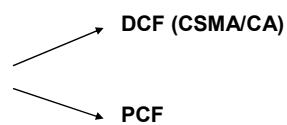

- **Distributed Coordination Function (DCF)**
 - ♦ Asynchronous data service
 - ♦ Optionally with RTS/CTS
- **Point Coordination Function (PCF)**
 - ♦ Intended for realtime service (e. g. VoIP)
 - ♦ Polling method
 - ♦ Optional

(C) Herbert Haas 2004/10/14

2

Superframe

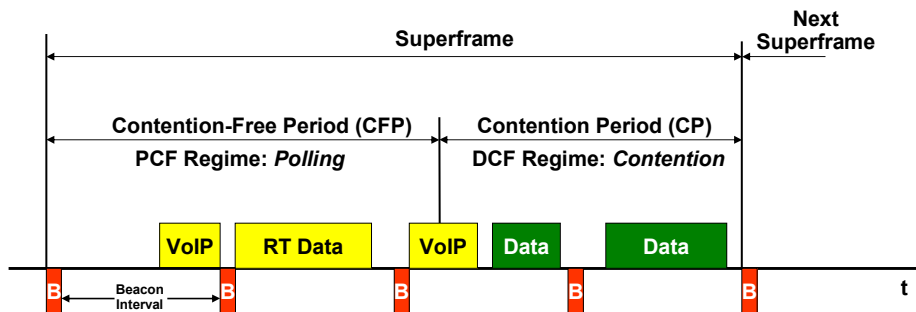

- Beacon is sent by "Point Coordinator" (PC=AP)
- Minimum CP period guaranteed
 - ♦ To avoid starvation of non-realtime data
 - ♦ At least one frame can be sent
- Note: Poll-Frames and ACKs omitted in this picture!

CSMA Access Method

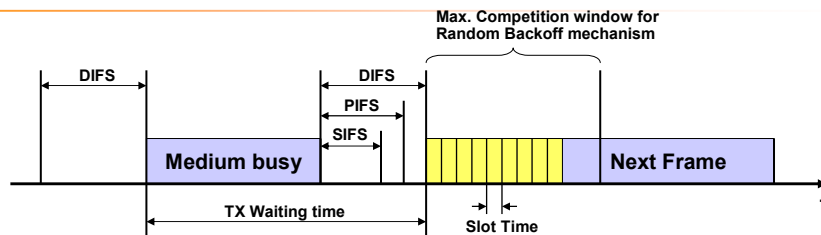

Basic Ideas

- No standing waves in free space => no Ethernet-like collision detection possible
- Collision is detected by missing ACKs!
- Truncated Random Exponential Backoff like in Ethernet and 802.3
- Simple fragmentation mechanism
 - ♦ Ethernet compatibility
 - ♦ Performance (interferences)
- CCA to determine medium state
- CSMA: "Listen before talk"
- A safety Inter-frame Space (DIFS | PIFS | SIFS, plus Backoff) must be awaited before TX

Details

- CW is multiple of Ethernet slot time
 - ♦ If medium is busy: Backoff
 - ♦ Slot time: 47 μ s (9 μ s)
- DCF Inter-Frame Space (DIFS)
 - ♦ Longest waiting time, 128 μ s (34 μ s)
 - ♦ Used for asynchronous data services
- PCF Inter-Frame Space (PIFS)
 - ♦ Used for APs to stop user communication, 78 μ s (25 μ s)
- Short Inter-Frame Space (SIFS)
 - ♦ Shortest waiting time, highest priority, 28 μ s (16 μ s)
 - ♦ Used for ACKs

Backoff Policies



- Random backoff reduces collisions
- Competition window (CW)
 - ♦ Start value of 7 slot times
 - ♦ After every collision → CW doubled
 - ♦ To a max of 255
- Post-backoff
 - ♦ After successful transmission
 - ♦ To avoid "channel-capture"
- Exception: Long silent durations
 - ♦ Station may send immediately after DIFS

CSMA/CA in Action

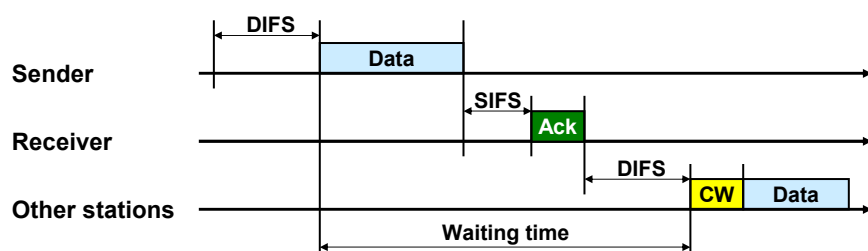

- Point-to-point communication
- Acknowledgment is send after SIFS
 - ♦ Before all other communications
 - ♦ Guaranteed collision free
- Re-transmitted frames have no higher priority over other frames

CSMA/CA with RTS/CTS Access Method



- Avoid the problem of invisible devices or "Hidden Stations"
 - ♦ Station receives data from two other devices
 - ♦ The two other devices didn't see each other
 - ♦ Each device thinks medium is free → Collision
- 2 special packets → RTS and CTS
 - ♦ Every station must listen to this packets

Four-way handshake:

1. RTS
2. CTS
3. Data
4. ACK

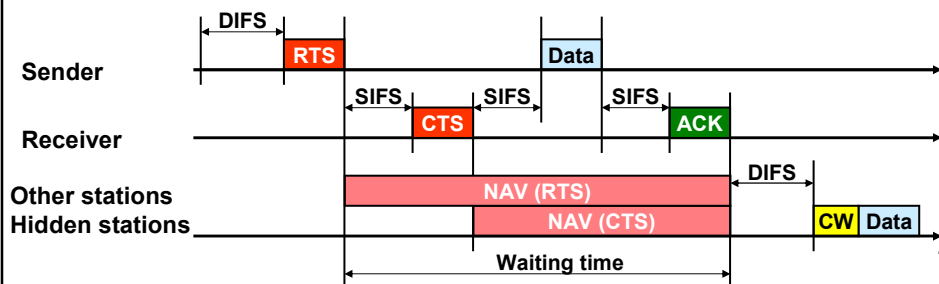

(C) Herbert Haas 2004/10/14

7

RTS/CTS => "Virtual Reservation"



- Collision can only occur at the begin or after a transmission
- Much more overhead
 - ♦ RTS/CTS packets increase the total access-delay
- Usage guidelines
 - ♦ Only when longer frames are sent on average (> 500 Bytes)
 - ♦ When hidden stations are expected

(C) Herbert Haas 2004/10/14

8

PCF – Polling Principle

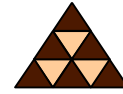

- **Guaranteed transmission parameters**
 - ♦ Minimum data rate
 - ♦ Maximum access-delay
- **AP necessary (!)**
 - ♦ For medium access control
 - ♦ Polling and time-keeping
 - ♦ Acts as "point coordinator"
- **Point Coordinator (PC) splits access time into a Superframe**
 - ♦ Contention-free period (PCF method)
 - ♦ Contention period (DCF method)
- **Target Beacon Transmission Time (TBTT) is announced in each beacon**

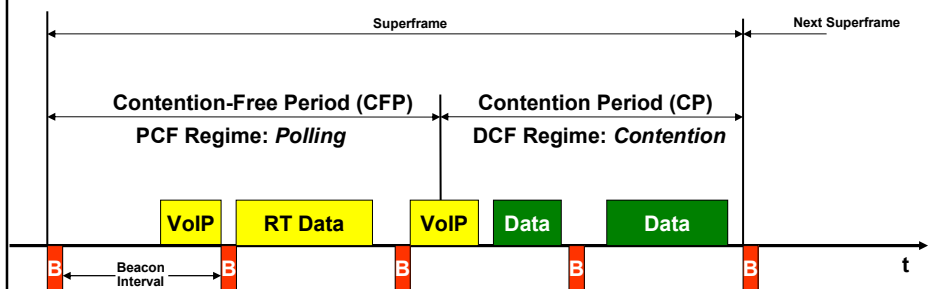

CFP Policy



- **Beacon starts CFP by announcing maximum duration of CFP**
 - ♦ Can be multiple of Beacon intervals
 - ♦ Intermediate Beacons indicate the remaining CFP duration
- **Between two successive CFPs there must be space to send at least one frame in the CP mode!**
- **The AP may finish the CFP earlier!**
 - ♦ Sending the CF-End Control Frame
- **CFP is optional**
 - ♦ CSMA/CA-only clients must not interfere
 - ♦ CFP also relies on CSMA/CA

PCF Medium Access

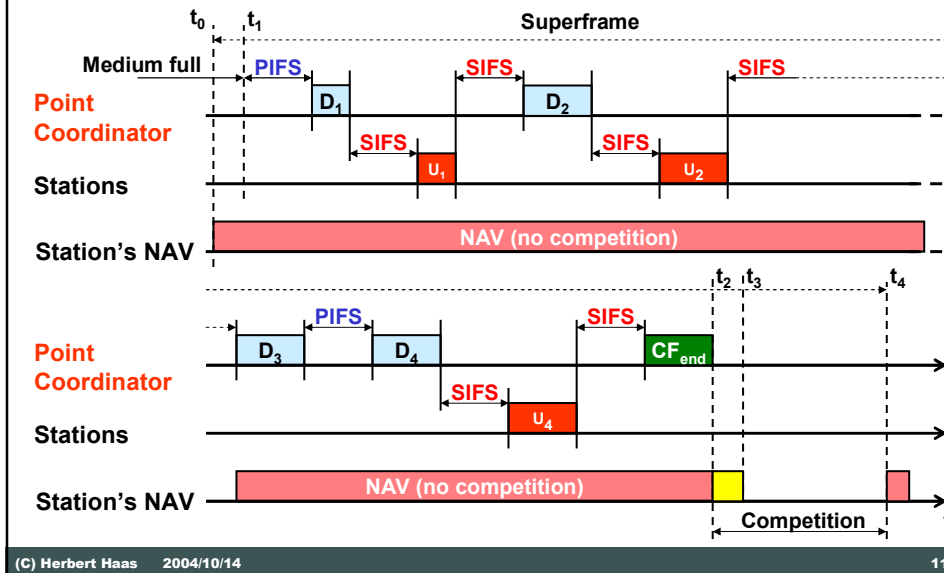

PCF Algorithm



- At t_0 starts the competition free zone
- Medium gets free at t_1
- After PIFS the PC can access the medium
 - ♦ No other station can access because PIFS is smaller than DIFS
- Now PC polls first station (D1)
- Stations may answer with user data after SIFS
- Stations must Ack within PIFS
 - ♦ PIFS is shortest idle period within CFP
- All frames are sent through AP !!!
- AP maintains list of all stations that should be polled
 - ♦ Announced by association process
 - ♦ PC continuously polls listed stations
- PC can send data together with beacon (piggy-back)
- By sending a CF_{end} frame the PC starts the CP

802.11g/b Compatibility

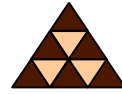

- **"b" expects CCK preamble and cannot detect OFDM signals**
 - ◆ Therefore collisions with legacy "b"
- **Compatibility mode**
 - ◆ g-devices only use RTS/CTS
 - Always 1 Mbit/s and BPSK
 - Newer "g" sends a CCK-based CTS before each OFDM-based data frame
 - ◆ "g" suffers from reduced throughput
 - 8-14 Mbit/s instead of 22 Mbit/s
- **"g" reaches longer distances (=>OFDM)**
 - ◆ Cell design must consider b-only clients
 - ◆ Only when same power level used !