

X.25

Slow, Safe and Reliable

What is X.25 ?



- **Connection-oriented Packet Switching**
- **WAN Technology**
- **Specifies User to Network Interface (UNI)**
- **Does **not** specify network itself (!)**

X.25 is wide area network service which is based on the virtual circuit technique. X.25 works only as a user to network interface (X.25 - DTE (e.g. router) \leftrightarrow X.25 - DCE (packet switch)). So its connection oriented and based on the store-and-forward principle of packets (packet switching technology).

Roots of X.25



- **Created by CCITT for Telco data networks in 1976**
 - ◆ Example: Datex-P
- **Adopted and extended by ISO**
 - ◆ Defined as OSI-layer 3 protocol

X.25 had been created in 1976 by the CCITT (today ITU-T) as data communications technology. Thus Telcos were able to offer data communication interfaces to the customers. Later this idea had been adopted by the ISO because X.25 perfectly fitted in the OSI model (layer 3).

Features



- **Reliable**
 - ◆ **Flow control and error recovery on layer two**
 - ◆ **Optionally on layer three**
 - ◆ **Can be used on bad links**
- **Secure**
 - ◆ **Often used with encryption**
 - ◆ **Network checks caller-ID**
- **High accountability**

X.25 technology was developed for low quality, low speed lines. Because X.25 use error recovery and flow control on layer 2 to control transmission of frames over physical lines and also use flow control and optionally error recovery on layer 3 to control transmission of packets over a virtual circuit, X.25 is very safe and can be used on very bad links. X.25 is world wide available and mostly used for transaction today (Visa).

X.25 Network

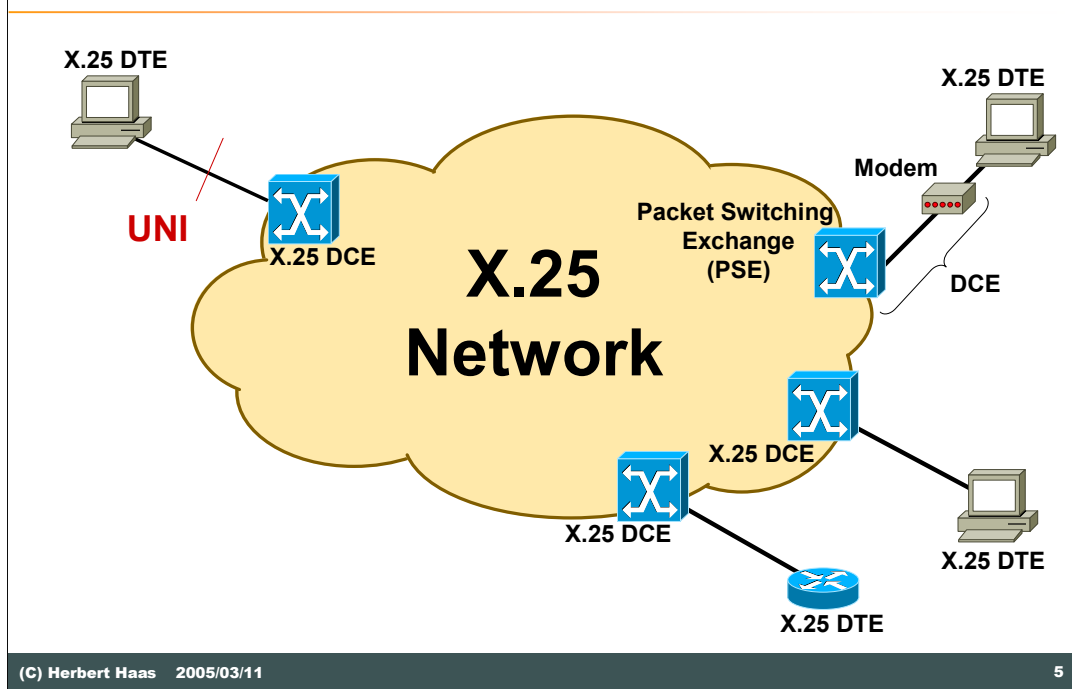

(C) Herbert Haas 2005/03/11

5

The network consists of three components:

- 1) Data terminal equipment (DTE), which is actually the user device and the logical X.25 end-system
- 2) Data communication equipment (DCE, also called data circuit-terminating equipment), which consists of modem and packet switch
- 3) Packet Switching Exchange (PSE), or simple: the packet switch.

Logical Channels (1)

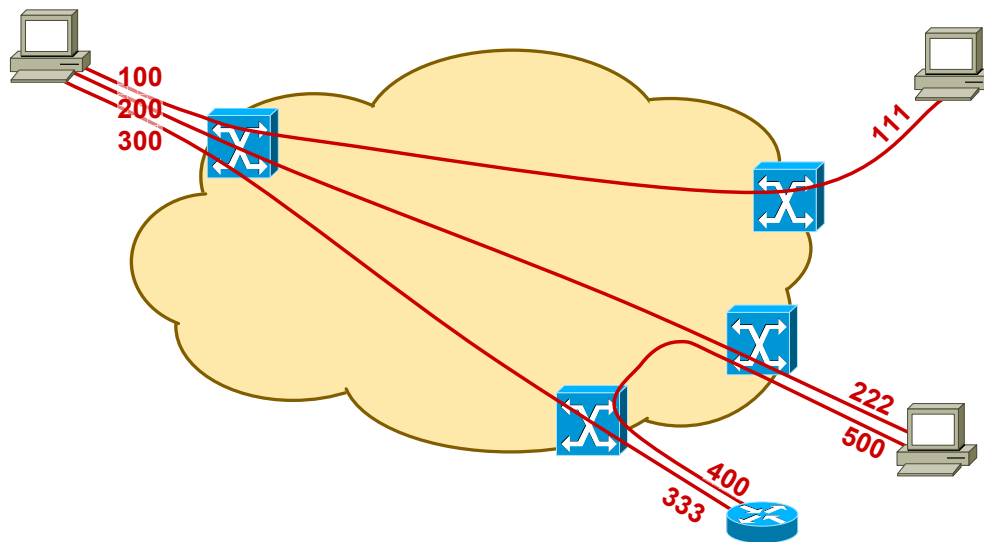

(C) Herbert Haas 2005/03/11

6

In the picture above you see the virtual circuit principle of X.25. For statistically multiplexing many logical data conversations were build over a single physical transmission link. With X.25 a user build a “virtual pipe” to the destination host.

Logical Channels (2)



- **Logical Channel Number (LCN)**
 - ◆ Identifies connection
 - ◆ Local significance only (!)
- **PVCs or SVCs**
- **Store and Forward Technology**
 - ◆ Variable delays (!)

One of the most important things of X.25 is the logical channel number (LCN). Virtual circuits are identified using these LCN numbers, which identifies the connection.

Virtual circuits appear to end systems as transparent transport pipes (logical point-to-point connections).

X.25 Layer Model

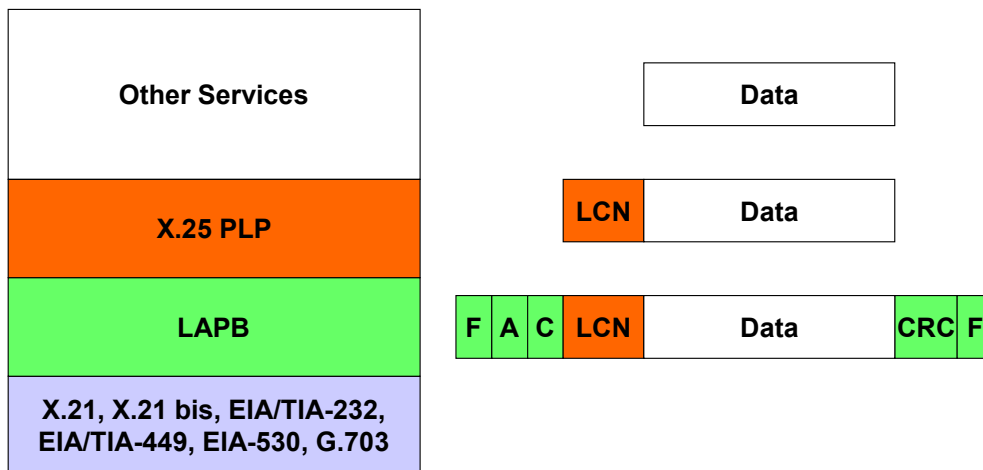

Several physical layer standards have been specified for X.25. One of the most important is X.21bis which defines mechanical and electrical interface issues. Using X.21bis allows synchronous transmission of data up to 19.2 Kbit/s.

X.25 PLP (1)



- **X.25 PLP**
 - ◆ **LCN (local significance) 0-4095**
 - ◆ **X.121 DTE-addresses (unique)**
 - ◆ **Virtual Circuit Services**
 - ◆ **Prioritizes precedence data**
 - ◆ **Flow control**
 - ◆ **Optional end-to-end error recovery (D-bit)**

LCN 0 (zero) is reserved for diagnostics.

X.121 addresses are structured (routable) addresses. It's a sequence of numbers associated to continent, country, city and so on.

Priority packets are sent using an interrupt-request. Each interrupt packet must be acknowledged by an Interrupt Confirmation packet before the next interrupt packet can be sent (Idle-RQ method). The length of Interrupt packets is only 32 bytes.

Flow control is based on windowing and RNR (RR) messages. Upon delay of acknowledgment, the receiver closes the send window of the sender (windowing). The default window size is 2. Optional end-to-end error recovery (GoBack N) can be achieved using the D-bit in the X.25 PLP header. In this mode, X.25 REJECT messages can be send.

X.25 PLP (2)

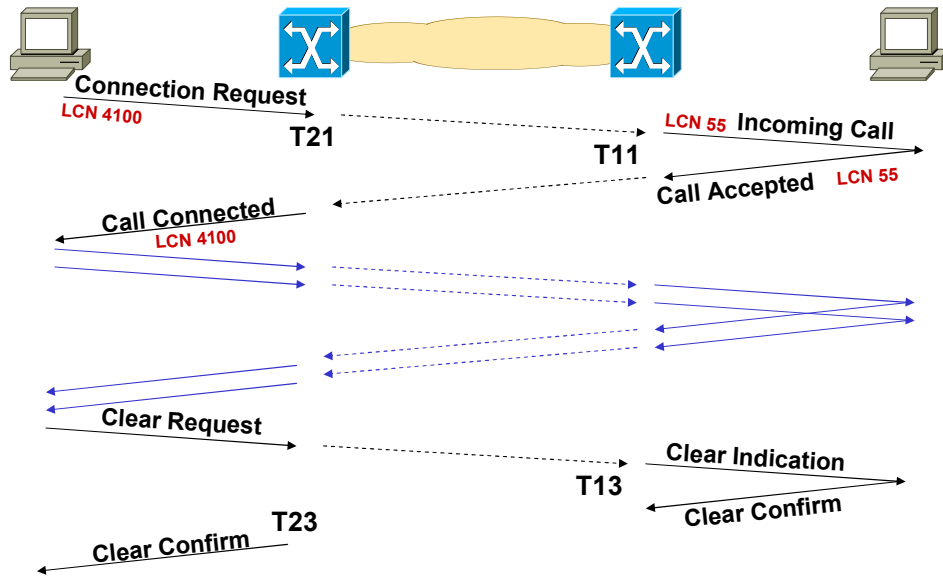

The above picture shows the basic call establishment procedure which is the task of layer 3 (X.25 PLP). Note that this layer is responsible for logical channel numbers so the X.25 PLP cares for (de)multiplexing of different virtual calls over the same physical media.

X.25 PLP Format

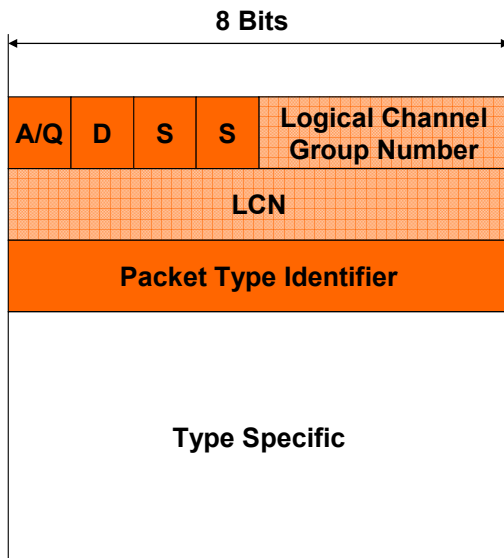

- **A = 1** escape from conventional X.25 addresses (1988)
- **Q...Qualifier bit**, used for normal data packets to indicate user or control data (not really explained)
- **Logical Channel Group Number + LCN = 4096** virtual channels
- **SS** specifies sequence number space (01=modulo 8, 10=modulo 128)

For example the Q-bit can be used for separating X.29 control information for PAD equipment, or QLLC header indication for SNA over X.25.

The logical channel group number (LCGN) could be used for traffic aggregation (compared to VPI/VCI in ATM) but mostly this field is just combined with the LCN.

Window=2 and D=0

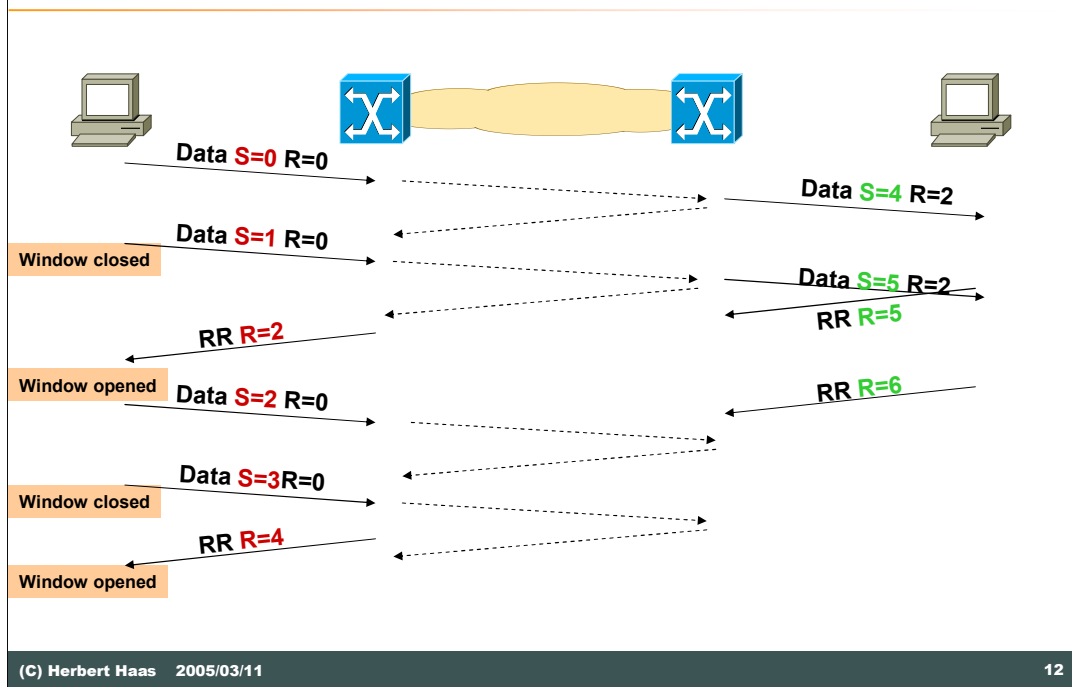

(C) Herbert Haas 2005/03/11

12

The above example shows an X.25 communication example without using the D bit. Here, data is reliably sent from the left PC (DTE) to the left switch (DCE) and from the left switch to the right (remote) switch. But as soon as a packet arrives on the remote switch, an acknowledgement is generated—actually there is no guarantee that this packet will arrive on the right PC (DTE). But in normal cases, the local link DTE-DCE is reliable enough because of LAPB.

Window=2 and D=1

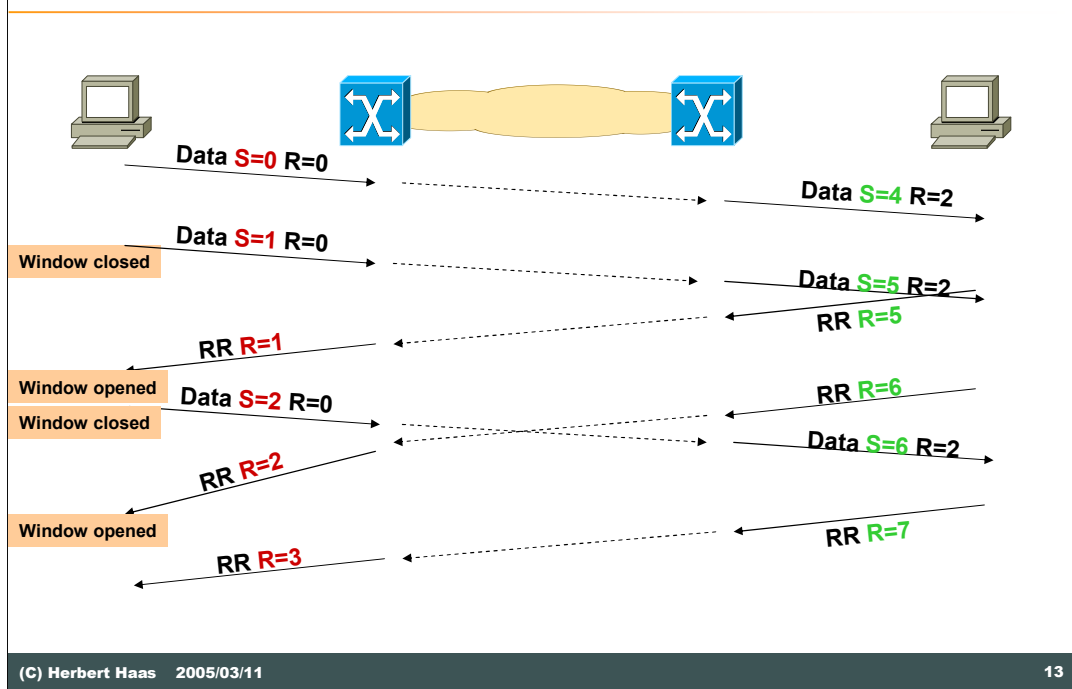

(C) Herbert Haas 2005/03/11

13

The above example shows the effect of an end-to-end acknowledgement which is provided if $D=1$. Additionally, it can be seen that the sequencing on the left side is completely decoupled from the sequencing of the right side. Consider the data packet sent with $S=2$. It arrives at the right switch shortly after right host sent $RR=6$. This $RR=6$ is transformed to $RR=2$ by left switch. Usually we might conclude that right host expects left host's packet with $S=3$. But right switch will send the current packet ($S=2$) as $S=6$. Note that both switches might have no idea of the sequence numbers used on the other sides.

X.121 Addresses



- **Public data network numbering (ITU-T)**
- **Only used to establish SVCs**
- **Aka International Data Number (IDN)**
- **4 + up to 10 digits**

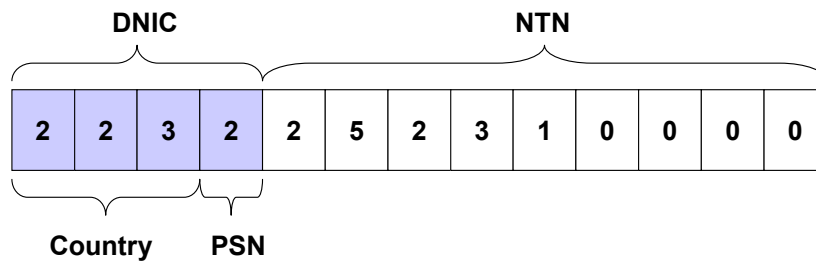

DNIC...Data Network Identification Code
NTN...National Terminal Number
PSN...Public Switched Network

The Data Network Identification Code (DNIC) is optional and typically omitted inside a specific public switched network.

The first digit in the DNIC identifies the zone. For example Zone 2 covers Europe and Zone 3 includes North America. The NTN identifies the DTE and can have up to 10 digits in length. It is possible to map an IP address into the NTN, see RFC-1236. By the way, the example address above belongs to the University of Vienna.

LCN Ranges



- **Outgoing requests succeed over coincident incoming calls with same LCN**
- **Predefined LCN ranges**
 - ◆ **Minimize propability of LCN collisions**

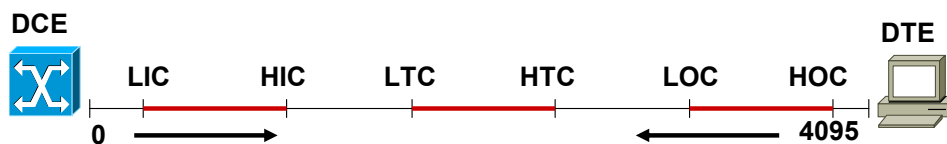

Three ranges can be predefined by the provider to avoid collisions. Two threshold markers are associated to each range. These are:

- 1) LIC (lowest incoming channel) and HIC (highest incoming channel)
- 2) LTC (Lowest two-way channel) and HTC (highest two-way channel) mark the range for incoming and outgoing channels
- 3) LOC (lowest outgoing channel) and HOC (highest outgoing channel)

X.25 Facilities (1)



- **Essential Facilities**
 - ◆ Provided by all X.25 devices
 - ◆ Have default values
- **Examples**
 - ◆ Maximum packet size (Default: 128 Bytes)
 - ◆ Window size
 - ◆ Throughput class (75, ..., 48000 bit/s)
 - ◆ Transit delay

The X.25 standard describes a number of so-called "facilities" that identify or enhance a X.25 session. There are two types of facilities: essential and optional.

X.25 supports various packet sizes up to 4 KB. The maximal data rate defined for X.25 is 2 Mbit/s.

X.25 Facilities (2)



- **Optional Facilities**
 - ♦ Don't need to be provides
 - ♦ Default values and negotiation possible
- **Examples**
 - ♦ Packet error recovery (REJ support)
 - ♦ Fast Select and Fast Select Acceptance
 - ♦ Closed user groups
 - ♦ Reverse charging
 - ♦ Hunt groups
 - ♦ Call redirection

Negotiation of optional facilities can be done in advance between user and service provider, by online-registration or during call setup.

REJ support means optional ARQ on layer 3. This service utilizes the so-called "D-bit" explained later. Fast Select allows to send data immediately with the first packet that is sent for connection establishment. This feature was invented especially for credit-card transactions to speed up this payment method. Closed user groups guarantee privacy so that only dedicated users can communicate – very important for commercial networks. Reverse charging is one of the unpleasant facilities. DTEs can be collected to a so-called hunt group to improve accessiblensness. If an incoming call occurs each DTE within a hunt group is alerted, following a predefined order. Call redirection is a comfortable feature that let others do your job.

Fragmentation (1)



- **Switch may fragment packets**
 - ◆ If one DTE requires smaller packet sizes
- **Using M-bit ("More")**
 - ◆ M=0 means unfragmented packet or last fragment
 - ◆ M=1 means first or middle fragment
- **Switch may combine packets in the reverse direction**

Fragmentation (2)



- **In case of end-to-end acks (D=1)**
 - ♦ We want an ACK for each sequence
 - ♦ Not for each fragment
- **Two types of packets**
 - ♦ In-sequence packets (M=1, D=0)
 - ♦ Single or end-sequence packets (M=0, D=1)

These two types of packets are also called category-A (in-sequence) and category-B (single or end-sequence) packets.



- **Link Access Procedures Balanced**
 - ◆ HDLC variant (ABM)
 - ◆ Error recovery and flow control
 - ◆ Addresses are useless on point-to-point links ⇒ used to separate commands and responses

Since LAPB utilizes the ABM mode there is no master/slave relationship. The P/F bit is used for check pointing purposes only, in cases when either end becomes unsure about proper frame sequencing because of a possible missing acknowledgement.

Point-to-point communication does not require any addressing scheme. However, HDLC provides addresses and so does LAPB. But LAPB utilizes this field to separate commands and responses. For example the address 0x01 is used for commands from DTE to DCE and responses to these commands from DCE to DTE. The address 0x03 is used for frames containing commands from DCE to DTE and associated responses from DTE to DCE.

Scope of Each Layer

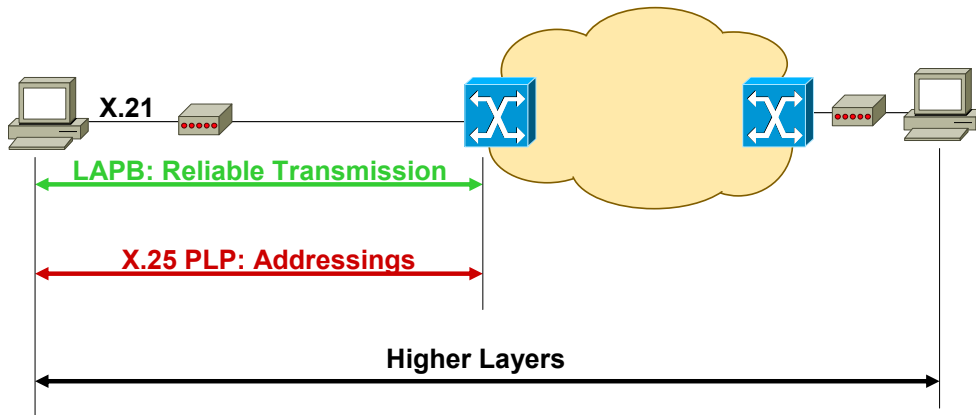

The picture above shows the basic idea and usage of X.25. Higher layer data is carried in X.25 packets that identify the associated virtual calls using a unique address information upon call set-up and LCNs afterwards. LAPB does not differentiate between virtual calls and therefore handles all packets equally. Remember that X.25 is an interface specification only (a UNI) and the internals of the "X.25 network" are not specified.

PAD (1)



- **Packet Assembler/Dissassembler (PAD)**
 - ◆ Commonly found in X.25 applications
 - ◆ Used when DTE is a character-oriented device
 - ◆ Too simple for full X.25 functionality
- **Three functions**
 - ◆ Buffering
 - ◆ Packet Assembly (chars to packets)
 - ◆ Packet Dissassembly (strips X.25 header)

The "Packet Assembler/Dissassembler" (PAD) is an optional device and necessary to connect a dumb asynchronous (character-oriented) device to the X.25 network. The PAD converts the byte-stream into an X.25 packet.

PAD (2)



Dumb character terminal (DTE)

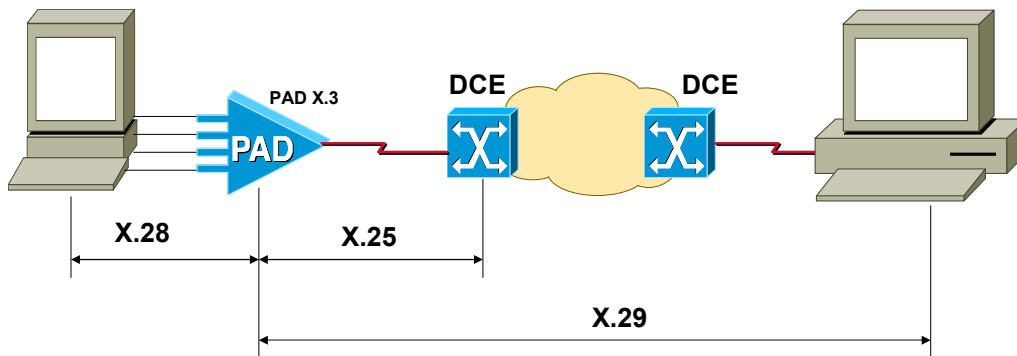

(C) Herbert Haas 2005/03/11

23

X.28 defines communication issues between a non-packet DTE and a PAD. X.29 defines how a PAD and a remote packet station may exchange control information. The remote station can be a packet-DTE or also a PAD. X.29 identifies these control packets using the Q-bit in the X.25 PLP header. Note that the X.29 protocol allows the configuration of a remote PAD.

The X.3 standard specifies the functionality of a PAD to handle different terminal types and determines how the PAD communicates with the user DTE. The X.3 standard specifies parameters such as escape from data transfer, data forwarding signal, terminal speed, flow control, linefeed, handling, echo, forward only full packets, forward a packet upon carriage return, send service signals to user, send interrupt packet upon receipt of a BREAK, etc.

X.75



- **Signalling system to connect two X.25 networks on international circuits**
- **Layer 2: LAPB**
- **Layer 3: X.75**
 - ◆ **X.75 is very similar to X.25 but includes a variable length field for network utilities**

Note that X.75 can also interconnect packet-switched networks other than X.25.

Summary



- **CCITT and ISO standard for connection oriented packet switching UNI**
- **LAPB for reliable link transmission**
- **X.25 PLP for VC services**
- **Slow – mostly used for transactions today**
- **World-wide available**

Note that ITU-T replaced the CCITT in 1993. The CCITT's origins go back to 1865.

Quiz



- **Who uses X.25 today?**
- **Do shops have both ISDN and X.25 separately installed?**
- **What is AX.25?**
- **How can we speed-up X.25?**

Hints



- **Q1: Chancelleries (ambassador's office), bank-terminals, airport-terminals, press agencies, Lotto,...**
- **Usually they put X.25 (VISA...) over D-channel. Also X.25 over B channels are in use.**
- **Q3: AX.25 is used for amateur packet radio. The difference is that the header must include the callsigns**
- **Q4: Reduce protocol overhead (double flow control and ARQ !) leads us to FR**