



# **Multiplexing Methods**

Daubing the Information



*“I think there is a  
world market  
for about  
five computers.”*



Thomas Watson,  
chairman of IBM 1943

If he was right then internetworking is useless and we can forget the whole chapter...

# Multiplexing Types



- **TDM**
    - ◆ **Most important**
    - ◆ **Statistical and Deterministic**
  
  - **SDM**
  - **FDM and (D)WDM**
  - **CDM**
- } Will be covered in other chapters

In this chapter we will discuss Time Division Multiplexing (TDM) techniques which is the most common transport technology used today.

TDM can be used in a deterministic way which means dedicated bandwidth and dedicated delay or in a statistical manner shared bandwidth and variable delay.

Nevertheless there are also some alternative multiplexing techniques available like:

- Space Division Multiplexing (SDM) - data is sent across physically separated media
- Frequency Division Multiplexing (FDM) – uses different electrical frequencies to transport data on one and the same physical media
- Dense Wave Division Multiplexing (DWDM) – mainly used in fiber optic systems, data is transported on separate wavelengths of light
- Code Division Multiplexing (CDM) – data is transported (and differentiated) by different types of code



## TDM (2)



- **Requires framed link layer**
- **Saves wires**
- **Is slower than SDM**
- **Requires multiplexers and demultiplexers**
- **Two fundamentally different methods:**
  - ◆ **Deterministic TDM**
  - ◆ **Statistical TDM**

To implement TDM data needs to be packed in frames especially in statistical TDM techniques. It saves network infrastructure costs because it needs much less physical medias than SDM systems.

TDM is obviously slower than SDM because the available bandwidth is shared between different communication channels and it requires devices that perform the multiplexing and demultiplexing task.

Deterministic TDM has constant delay and bandwidth and is used in techniques like ISDN, PDH or SDH.

Statistical TDM has variable delay and bandwidth and is used in technologies like X25, Frame-relay or ATM.

# Deterministic TDM (1)

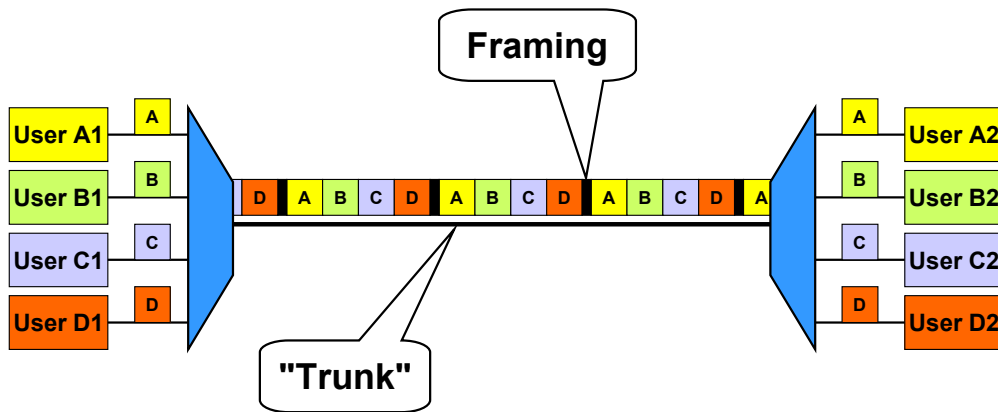

Deterministic TDM systems use transport frames like E1, T1, STM1, etc in which the actual data can be filled in transparently. The framing is needed for synchronization, network management and sometimes error detection functions between multiplexer and demultiplexer devices.

Each communication channel on a deterministic TDM connection is identified by its timely position inside the TDM frame. Principally no further headers or address information is required by the payload.

The major disadvantage of deterministic TDM systems is the fixed correlation between communication channel and time slot position. This means if one communication channel is not used it still occupies the time slot capacity by sending some kind of idle pattern.

## Deterministic TDM (2)

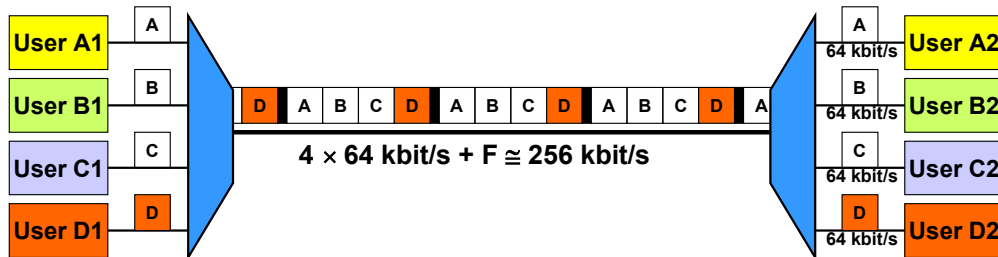

- **Trunk speed = Number of slots × User access rate**
- **Each user gets a constant timeslot of the trunk**

The bandwidth needed on a deterministic TDM trunk is always determined by the sum of all communication channels on the trunk plus some administrative overhead, because of the fixed correlation between communication channel and timeslot.

In our example we find four communication channels with a capacity of 64Kbits/s each, so the transport capacity of the trunk needs to be 256 Kbits/s.

## Deterministic TDM – Facts



- **Order is maintained**
- **Frames must have same size**
- **No addressing information required**
- **Inherently connection-oriented**
- **No buffers necessary (QoS)**
- **Protocol transparent**
- **Bad utilization of trunk**

In deterministic TDM systems the order of the data packets is maintained, no packet overtake or time slot position change is possible.

The frames need to have always the same size because the timeslots in deterministic TDM systems have a constant length.

Address information is not required, because the destination is determined by the time slot position.

Deterministic TDM is connection-oriented because a point to point connection is typically setup in SVC technique or permanent established in PVC technique.

Buffers are not needed because the data stream is sent out with exactly the same speed as it is received.

It is protocol transparent because theoretically no further packing is needed and the destination is determined by the timeslot position.

Bad trunk utilization could occur if only a few of the reserved timeslots are in use.

# Statistical TDM (1)

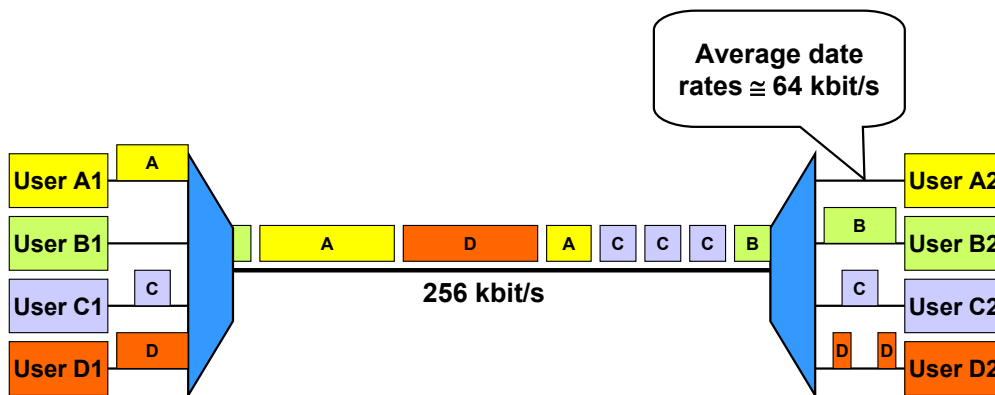

- Trunk speed dimensioned for **average** usage
- Each user can send packets whenever she wants

In statistical TDM systems there is no fixed correlation between timeslot position and communication channel as it is with deterministic TDM systems. Therefore the speed of the trunk could be chosen according to the average statistical transport needs of the users.

Any user is allowed to send data at any time. Of course a separate addressing and framing scheme needs to be used because the fixed correlation between timeslot position and destination is broken in these systems.

## Statistical TDM (2)

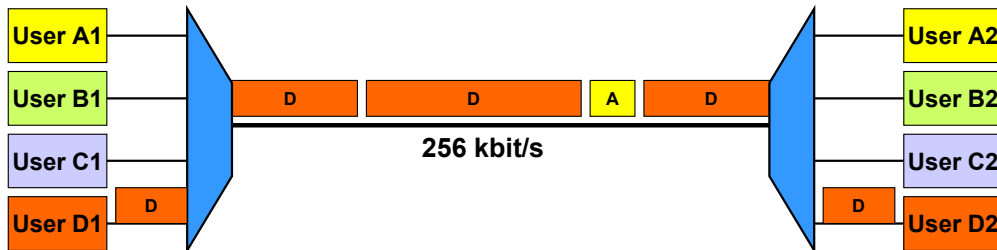

- **If other users are silent, one (or a few) users can fully utilize their access rate**

One of the major advantages of statistical TDM systems compared to deterministic TDM systems is the following fact: if the trunk is empty one user may use the complete transport capacity of the trunk.

On the other hand it may occur that all users want to use the trunk at the same time. Because of the statistical dimensioning of the trunk capacity it may happen that more data is fed in by the users than the trunk capacity allows.

For such cases buffers are needed by the statistical TDM devices to compensate the speed differences. In case of buffer overflow conditions it may even happen that data is lost.

## Statistical TDM – Facts



- **Good utilization of trunk**
  - ◆ **Statistically dimensioned**
- **Frames can have different size**
- **Multiplexers require buffers**
- **Variable delays**
- **Address information required**
- **Not protocol transparent**

Statistical TDM allows a good utilization of the trunk because there is no waste of bandwidth by the use of idle patterns and the capacity is determined by the average needs of the users.

The frame size may vary depending on the need of the users.

Buffering is required under trunk overload conditions.

The delay is variable because of buffering.

Address information is needed because of the lost correlation between time slot position and destination.

Statistical TDM is not protocol transparent because a separate packing as well as addresses are needed.

# Networking: Fully Meshed

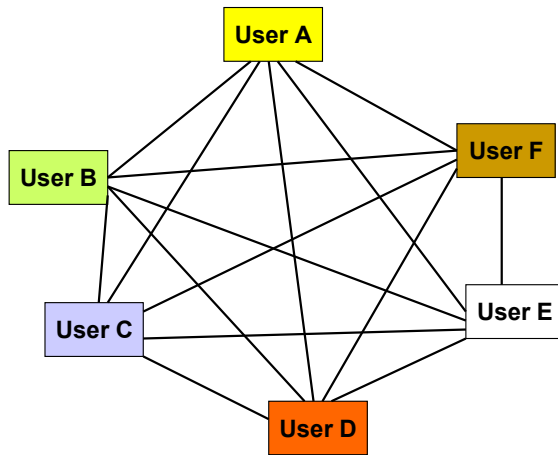

- **Metcalf's Law:**  
 $n(n-1)/2$  links
- **Good fault tolerance**
- **Expensive**

A fully meshed network is a thing that everybody wants, because it gives 100% redundancy and optimized data transport to each destination. But unfortunately only very few can effort it, because the costs of network infrastructure would grow with Metcalf 's law.

Which is expressed by the formula  $n \times (n-1)/2$  .This means if you have ten sites you want to connect in an any to any topology you would need 45 connections.

# Networking: Switching

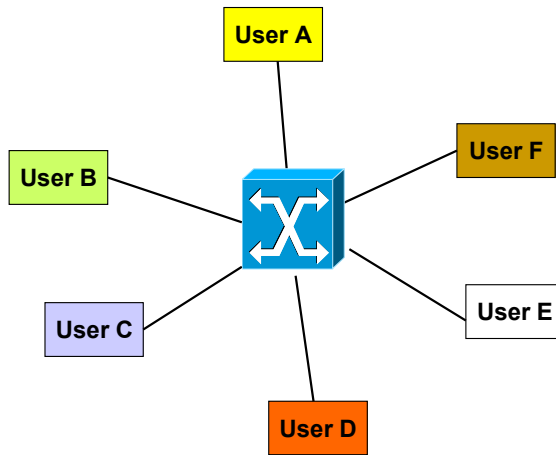

- Only 6 links
- Switch supports either deterministic or statistical TDM

One way to save costs would be the use of network switches, which are responsible for handling the traffic between the different destinations.

The switches may use a technology either based on deterministic or statistical TDM. In this case we would need only six links instead of fifteen links to establish communication between all sites.

# Circuit Switching

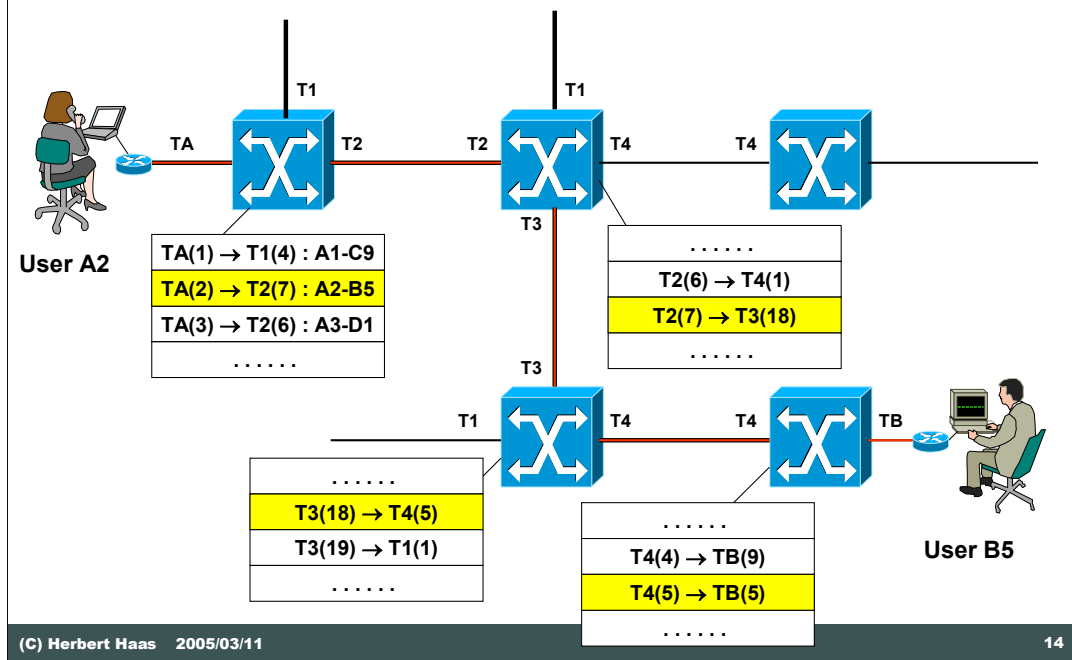

(C) Herbert Haas 2005/03/11

14

Circuit switching technology is based on deterministic TDM.

All network switches in circuit switching technology hold a switching table which determines the correlation between incoming trunk/timeslot and outgoing trunk/timeslot.

In our example the connection between user A2 and B5 is established by four network switches and their according switching tables. For both users this connection looks like a dedicated point to point link, they are not aware what's going on inside the network cloud.

# Circuit Switching – Facts



- **Based on deterministic TDM**
  - ◆ Minimal delay
  - ◆ Protocol transparent
  - ◆ Possibly bad utilization
  - ◆ Good for isochronous traffic (voice)
- **Switching table entries**
  - ◆ Static (manually configured)
  - ◆ Dynamic (signaling protocol)
  - ◆ Scales with number of connections!

Circuit switching based on deterministic TDM has minimal fixed delay, is protocol transparent, but may have bad network utilization due to currently unused connections.

So circuit switching is very well suited for isochronous traffic like voice communication or video conferencing. Circuit switching is the typical technology that is used by Telco's.

The switching table entries which are needed for proper data forwarding might be generated manually by the help of some network management software or dynamically by some signaling protocol.

# Typical User-Configuration

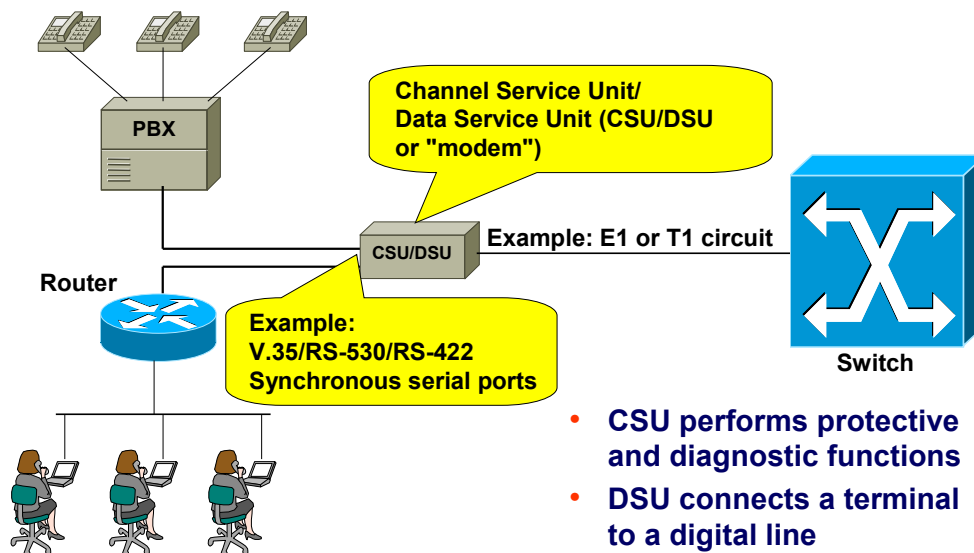

(C) Herbert Haas 2005/03/11

16

In real life a typical user configuration looks like the one shown in our example.

We find some users that are connected via a shared media to maybe a cisco router. The router itself is connected to a Channel Service Unit (CSU) or Data Service Unit (DSU) using an synchronous serial interface with a data rate of up to 2Mbit/s.

This CSU/DSU is responsible for terminating the TDM circuit which is supplied by the service provider as well as for the conversion between the synchronous serial interface and the TDM interface. In our scenario an PDH E1 (2048 Mbit/s) or T1 (1544 Mbit/s) circuit is used.

The connection supplied by the service provider might be shared between the router and the Private Branch Exchange. So the router uses reserved timeslots of the E1/T1 trunk for data traffic while the PBX is using some other timeslots to establish phone calls.

# Packet Switching

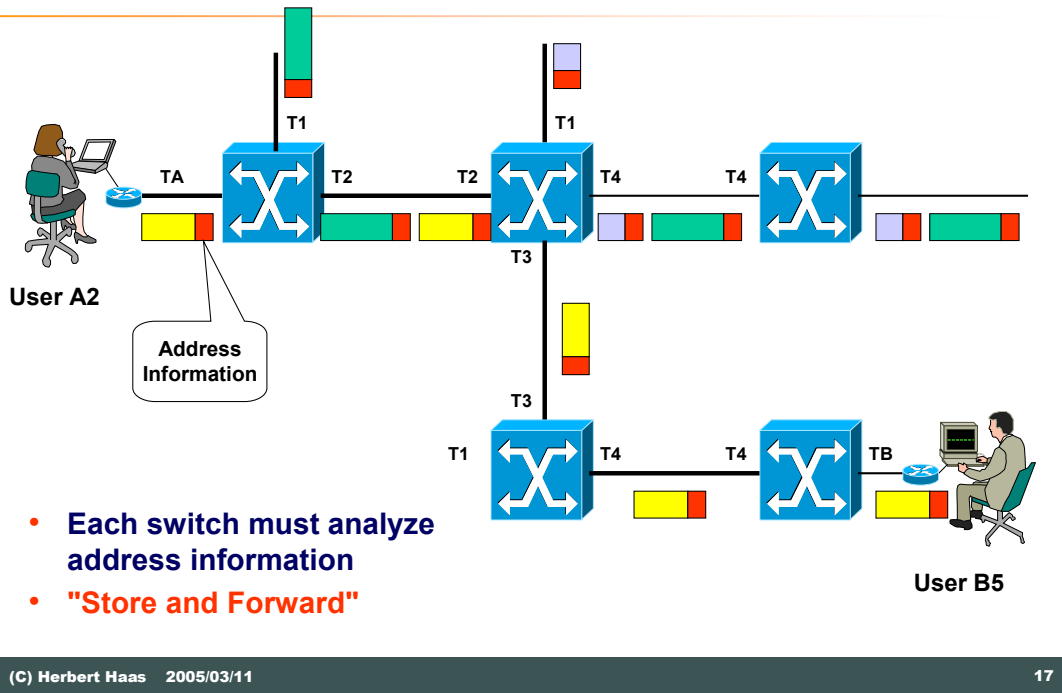

In packet switching technology which is based on statistical time division multiplexing addresses are needed, remember there is no correlation between timeslot and destination.

Each switch must analyze the destination address of every data packet to be able to forward it according to some forwarding table.

In our example user A2 communicates with user B2 by the help of addresses.

# Technology Differences



- **Datagram Principle**
  - ◆ **Global and routable addresses**
  - ◆ **Connectionless**
  - ◆ **Routing Table**
- **Virtual Call Principle**
  - ◆ **Local addresses**
  - ◆ **Connectionoriented**
  - ◆ **Switching Table**

There are two major technologies that make use of the statistical TDM principle. The Datagram principle which is using global unique and routable addresses. Data forwarding decisions are made by statically or dynamically generated routing tables and the data transport is connectionless. Examples for the Datagram principle are IP, IPX, Appletalk, etc.

The Virtual Call principle uses locally significant address well known under the term virtual circuit identifier. The data transport is done connection-oriented and the forwarding decisions are made by switching tables. The switching tables hold the information about incoming trunk/circuit identifier and the corresponding outgoing trunk/circuit identifier. Examples for Virtual Call services are X25, Frame-relay, ATM, etc.

# Datagram

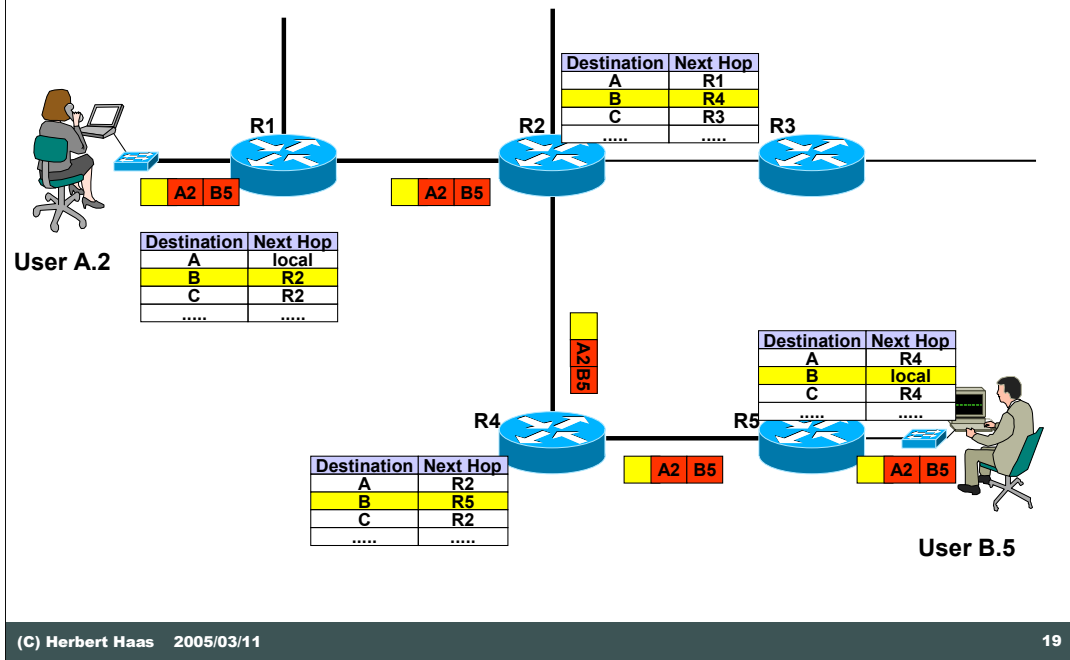

(C) Herbert Haas 2005/03/11

19

In the Datagram technology user A.2 sends out data packets destined for the user B.5. Each single datagram holds the information about sender and receiver address.

The datagram forwarding devices in our example routers hold a routing table in memory. In the routing table we find a correlation between the destination address of a data packet and the corresponding outgoing interface as well as the next hop router. So data packets are forwarded through the network on a hop by hop basis.

The routing tables can be set up either by manual configuration of the administrator or by the help of dynamic routing protocols like RIP, OSPF, IS-IS, etc. The use of dynamic routing protocols may lead to rerouting decisions in case of network failure and so packet overtaking may happen in these systems.

# Datagram – Facts (1)



- Addresses contain **topological** information
  - ♦ Must be **globally unique**
- Routing table is configured
  - ♦ Static (manually)
  - ♦ Dynamic (**routing protocols**)
- Endless circling in case of routing loops
  - ♦ Important issue among routing protocols
- Requires "**routable**" or "**routed**" protocols

The addresses used in datagram service technologies need to be unique and structured. Structured means a part of the address is reserved for the user identification while another part of the address is used for topology information (describes network where the user is located).

As already mentioned routing can be based on static configuration or dynamic routing protocols.

In case of inconsistent information held in routing tables routing loops may occur which would lead to endless circling packets. Some protocols like IP use a maximum Time to Live field in their header to get rid of the endless cycling data packets.

Networks which are build on the datagram service technology typically need two different types of protocols routed protocols which are used by the end user and routing protocols between routers to build up the routing tables.

## Datagram – Facts (2)



- **No connection establishment necessary**
  - ◆ **Faster delivery of first data**
  - ◆ **No resource reservation (bad QoS)**
- **Sequence not guaranteed**
  - ◆ **Rerouting on topology change**
  - ◆ **Load sharing on redundant paths**
  - ◆ **End stations must care**

Datagram services are typically driven in an connection-less mode, this guaranties a slightly faster delivery of datagrams because the time to establish a connection is saved.

The reservation of resources for QoS support is very difficult because the path of the data packets through the network may change during one session.

Topology changes cause rerouting when dynamic routing protocols are used and load sharing is practiced in the case of two or more paths with identical distance towards the destination. Rerouting and load balancing may also lead to packet overtaking, so the correct order of data packet arrival is not guaranteed.

## Datagram – Facts (3)



- **Best effort service**
  - ◆ Router may drop packets
  - ◆ Reliable data transport requires good transport layer ("Dumb network, smart hosts")
- **Simple protocols**
  - ◆ Easy to implement (Internet's success)
- **Proactive flow control difficult**
  - ◆ Since routes might change

Networks based on datagram technology support only best effort service, this means as good as it gets.

Routers that drop data packets because of buffer overflow or other problems don't care about error recovery. Error recovery is a task that needs to be performed by the end stations of a network. They have to take care for retransmissions in case of packet loss or transmission errors. This is typically done by layer 4 protocols like TCP which uses a connection-oriented mode.

Due to this behavior of a datagram networks, the protocols to drive this kind of network can be kept simple.

Proactive flow control is also very difficult to establish because paths and so transport capacities may change while data packets travel through the network.

# Examples



- IP
- IPX
- Appletalk
- OSI CLNP

Remember typical examples of datagram networks are IP, IPX, Appletalk and the quite unknown OSI CLNP protocol stack.

# Virtual Call – CR

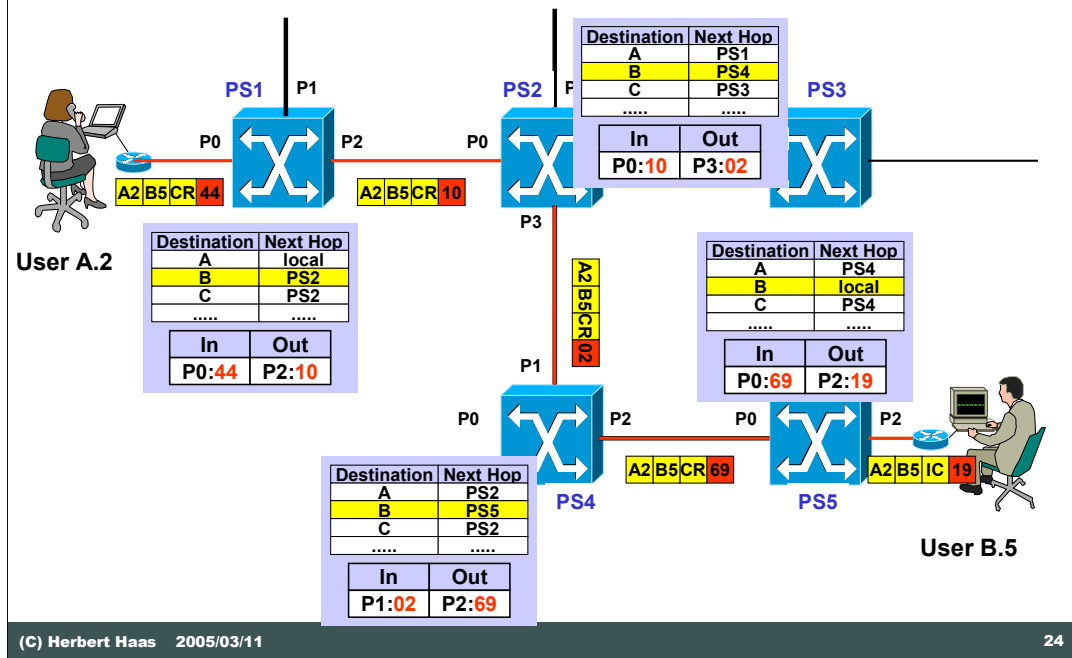

(C) Herbert Haas 2005/03/11

24

In Virtual Call Service technology addresses are used as well, but in a different manner than compared to datagram services. The address information in Virtual Call Service systems is only used at the beginning of a conversation to setup a connection.

With an established connection data packets are forwarded according to virtual circuit identifiers which are held in switching tables.

In our example user A.2 sends a connection setup request to user B.5. This connection setup request is forwarded by the network under the use of routing tables. This routing tables can be configured manually by an administrator or dynamically by the help of routing protocols e.g. PNNI.

# Virtual Call – CA

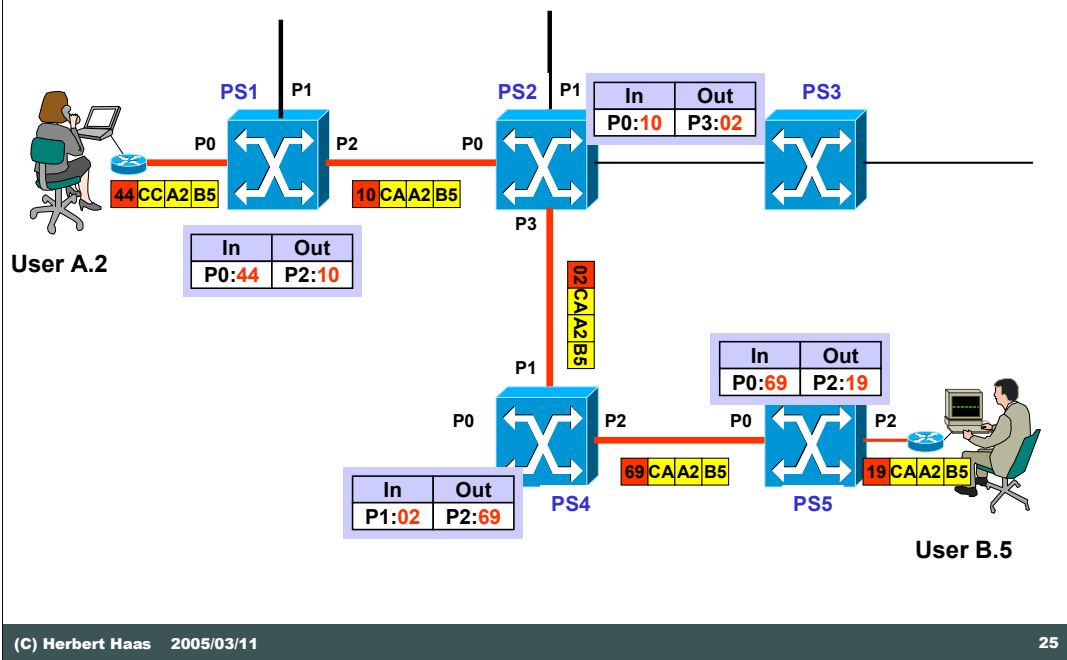

(C) Herbert Haas 2005/03/11

25

The connection setup request builds up a tunnel-like connection of virtual circuit identifiers held in switching tables.

User B.5 hopefully answers with a connection accept message back through the already established tunnel. From now on only switching tables with their circuit identifiers are used to forward the data packets.

The entries in the switching tables are created dynamically during the connection setup procedure by each network node.

# Virtual Call – Data

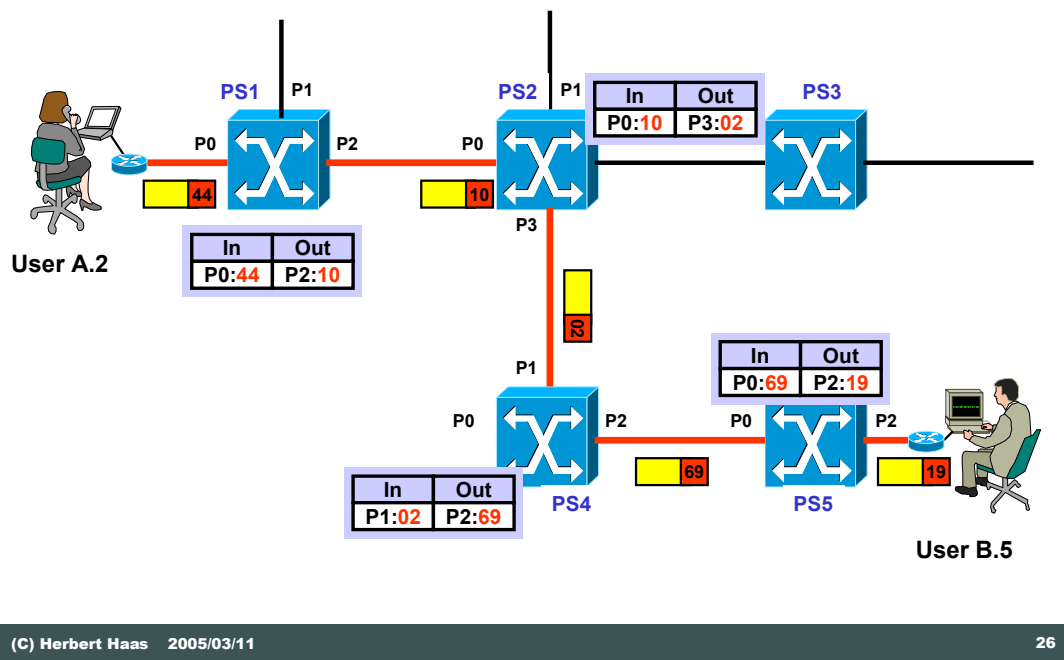

(C) Herbert Haas 2005/03/11

26

During the data transport phase there is no more need for addresses.

Data packets are forwarded using virtual circuit identifiers, which change on a hop per hop basis. Circuit identifiers have only local meaning in combination with their according trunk connection.

This behavior also prevents things like packet overtaking and makes it easier to implement QoS technologies in the network.

If a connection between two nodes is lost due to network failure, a new connection is established, starting with the connection setup procedure right from the beginning.

# Virtual Call – Facts (1)



- **Connection establishment**
  - ♦ Through routing process (!)
  - ♦ Globally unique topology-related addresses necessary
  - ♦ **Creates entries** in switching tables
  - ♦ Can reserve switching resources (QoS)
- **Packet switching relies on local identifiers**
  - ♦ Not topology related
  - ♦ **Only unique per port**

Remember routing processes are needed even in Virtual Call Service technologies to allow the setup of a connection. The addresses used for connection setup need to be structured and globally unique.

The connection setup procedure creates entries in switching tables to support the data forwarding phase.

It's quite easy to reserve transport resources (QoS) during connection establishment, because the path through the network remains the same for one conversation.

Data packet forwarding is performed according to local and only per port unique virtual circuit identifiers.

## Virtual Call – Facts (2)



- **Packet switching is much faster than packet forwarding of routers**
  - ◆ Routing process is complex, typically implemented in software
  - ◆ Switching is simple, typically implemented in hardware

Why is routing slower? We give just a short explanation here: First, a router must determine which part of the address is topology relevant – with IP addresses this so-called network-identifier has variable length. Second, the router must find the best ("longest") match of the destination net-ID with the routing table entries. Third, the next-hop might not be the physical next hop. In this case a recursive routing table lookup is necessary. Fourth, because of the topology-related addresses (and the associated complex forwarding processes) the routing table cannot easily be stored in a high-performant data structure. All this is typically implemented in software.

Switching is completely different. The addresses are unstructured and not topology related. The switching process is simply to look up the correct entry in the switching table and determine the outgoing interface, hereby modifying the logical channel number (the local connection identifier). The whole process can be implemented in hardware. Additionally, switching is greatly accelerated using hashing-functions (CAM-tables).

## Virtual Call – Facts (3)



- **Connection can be regarded as virtual pipe**
  - ◆ Sequence is guaranteed
  - ◆ Resources can be guaranteed
- **Network failures disrupt pipe**
  - ◆ Connection re-establishment necessary
  - ◆ Datagram networks are more robust

Remember a connection used by Virtual Call Service technologies can be seen like a virtual pipe or tunnel. Therefore the correct sequence of data packets is guaranteed and resources can be reserved quite easily.

Network failures will lead to a tear down of the connection and a new connection setup procedure.

Datagram networks are more robust because to setup a proper connection is more difficult than data packet forwarding on a hop by hop basis. The connection setup procedure needs more sophisticated protocols especially when QoS parameters should be taken into account.

## Virtual Call – Facts (4)



- **Virtual call **multiplex****
  - ◆ **Multiple virtual pipes per switch and interface possible**
  - ◆ **Pipes are locally distinguished through connection identifier**
- **Other names for connection identifier**
  - ◆ **LCN (X.25)**
  - ◆ **DLCI (Frame Relay)**
  - ◆ **VPI/VCI (ATM)**

All WAN-switching technologies utilize the same principle that has been described above. But the connection identifier has different names. In X.25 we call it the Logical Channel Number (LCN). With Frame Relay we talk about the Data Link Connection Identifier (DLCI). And ATM packets are switched using the Virtual Path Identifier/Virtual Circuit Identifier (VPI/VCI). No matter what complicated names are used, it is simply a dumb identifier without any special meaning.

## Example

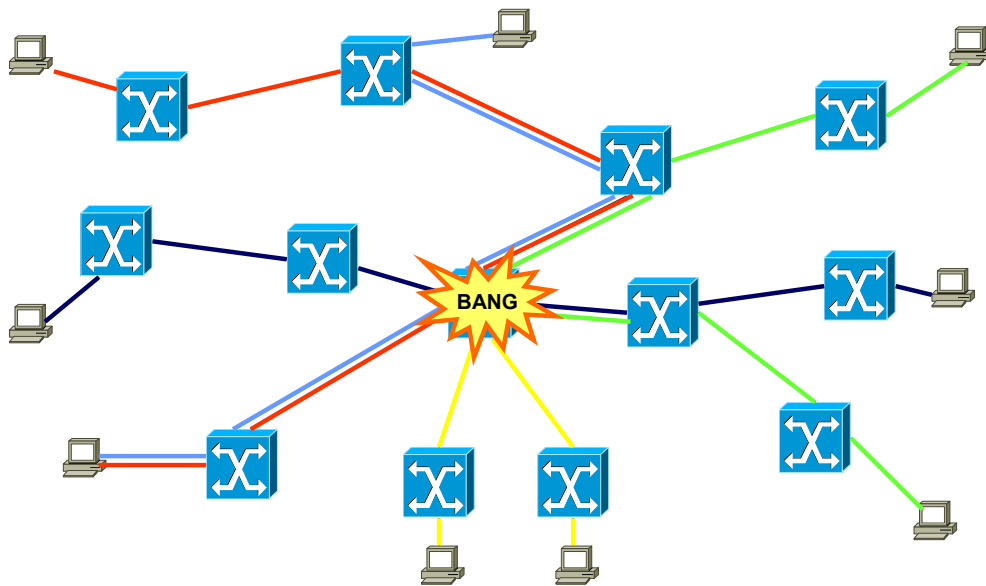

(C) Herbert Haas 2005/03/11

31

This example shows us what will happen if a node in the center of a network collapses. All connection through the collapsed node are torn down and new connections using signaling needs to be established. This causes a lot of overhead through to new connection setup requests. In Virtual Call Service technology its up to the end devices to set up a new connection through the network.

In Datagram technology this problem would be fixed by the network itself by rerouting.

## Two Service Types



- **Switched Virtual Circuit (SVC)**
  - ◆ Dynamic establishment as shown
  - ◆ At the end a proper disconnection procedure necessary
- **Permanent Virtual Circuit (PVC)**
  - ◆ No establishment and disconnection procedures necessary
  - ◆ Switching tables preconfigured by administrator

In Virtual Call Service technique we find two basic types of connections Switched Virtual Circuits (SVC) and Permanent Virtual Circuits (PVC).

SVC's dynamically establish a connection when needed and tear down the connection when the data transfer is finished. SVC technique is mainly used in combination with X25 and ATM services.

PVC's are permanently up and can be seen like leased line services. PVC's are mainly used in Frame-relay and ATM services.

# Taxonomy

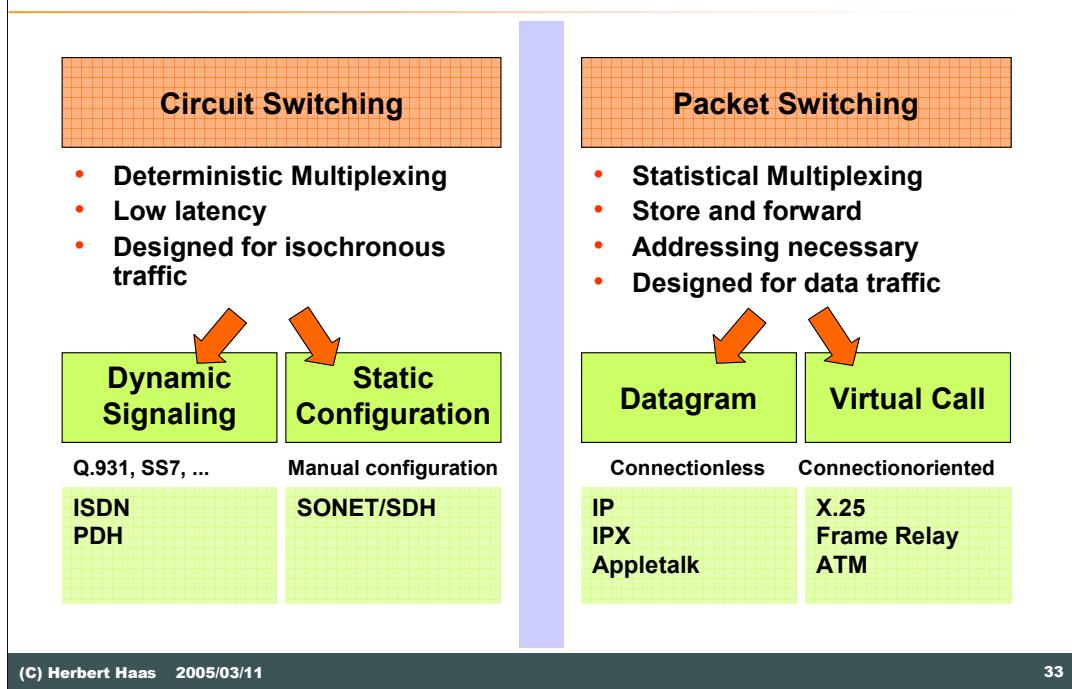

(C) Herbert Haas 2005/03/11

33

This slide gives us an overview about the TDM technologies discussed so far. On the top of this graphic we find the two basic flavors of TDM systems circuit switching based on deterministic TDM and packet switching based on statistical TDM.

Current circuit switching technologies are ISDN and PDH systems which can be used for SVC services using the signaling protocols Q931 and Signaling System Seven (SS7) or based on PVC technique using manually configured SONET/SDH channels.

Current packet switching technologies can be split up in Datagram Services like IP, IPX etc. or Virtual Call Services like X25, ATM, Frame-relay etc.

# Summary



- **Only two worlds: circuit switching or packet switching**
  - ◆ The first is good for voice the latter is good for data
  - ◆ Everybody wants to have the best of both worlds
- **Datagram (CL) versus Virtual Call (CO)**
  - ◆ Different address types (!)

# Synchronization Revisited

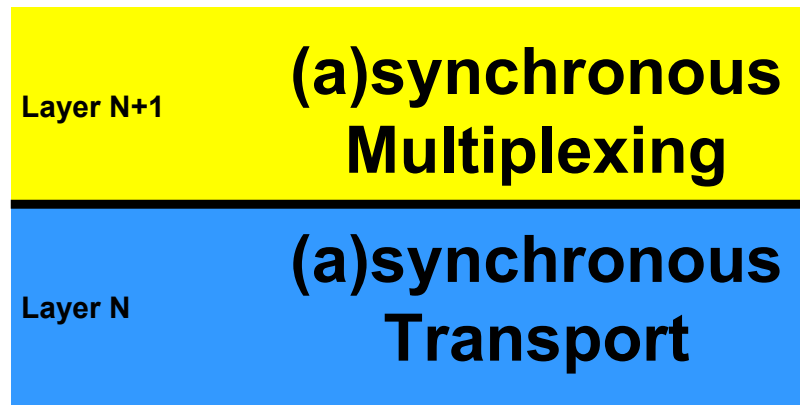

This slide wants to tell you that the world is not black and white only, but is always made up of some kind of colored grey.

The same is true for networking. Networks are made up of layers and each layer has its own identity and properties with interfaces to the next higher or lower layer.

So its quite easy to take a synchronous layer and put something asynchronous on top of it. Like ATM on top of SONET/SDH.

## Quiz



- **Derive Metcalfe's law. Which well-known formula looks very similar?**
- **Let's improve the VC principle! What's the advantage of using more than one label per packet?**
- **How do hash tables work?**
- **How can we get the best of both worlds (circuit/packet) ?**

# Hints



- **Q1:  $n$  users have  $n-1$  connection to the  $n-1$  other users. Divide this by 2 because of two-way lines. Aka Gauss formular to get the  $\text{sum}(1..n-1)$**
- **Q2: Traffic aggregation, fewer switching-table entries (MPLS, ATM)**
- **Q3: Index = hash (key) where hash is typically a modulo-prime operation**
- **Q4: Cells, good queuing algorithms, HW-based routing, MPLS, ATM, optical packet switching**